



Original Line Electric®



Electric motion control solutions
for extreme precision and
customized performance



Bimba Original Line Electric® Actuators

Bimba Original Line Electric® actuators provide the greatest feature set, versatility, and performance at a price you can afford.

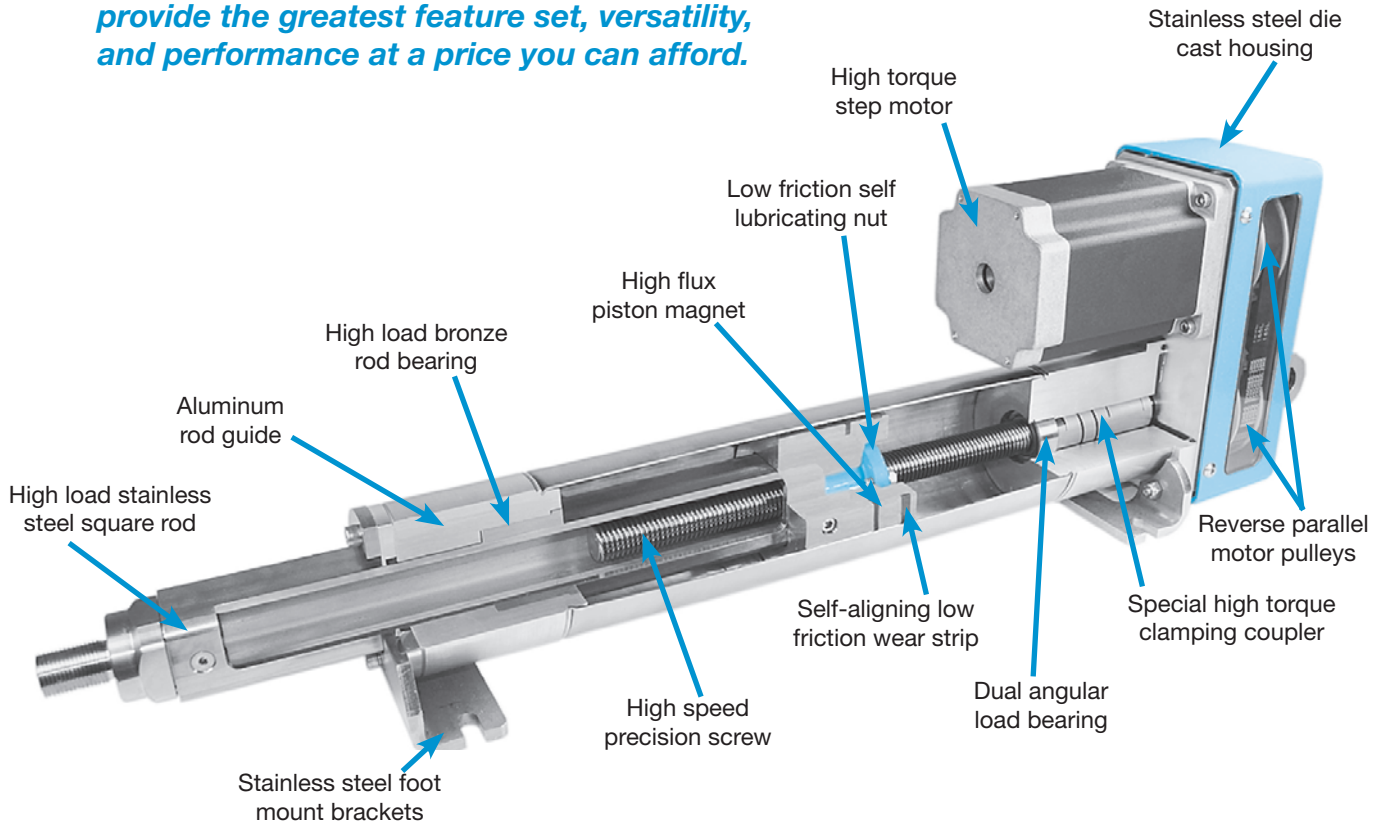

Original Line Electric® (OLE) actuators are alternatives to pneumatics where plant air quality, compressor availability, portability, and precise control and positioning are needed.

The model above is OLE-3508-20S-P3W; 350 series, 8 inch stroke, reverse parallel motor mount, 0.20 inch lead. The self locking thread holds the rod in position, even with no power to the motor. Using a 34-frame stepper, the actuator is capable of about 350 pounds thrust at 1 inch/second, or 50 pounds at about 6 inches/second. Two other leads enable speeds up to 24 inches/second.

Features	Benefits
• Modular design	• Order exactly what you need: actuator, motor, and driver, actuator and motor, or actuator only
• Special screws	• High speeds, high precision, and enables longer standard strokes
• Special composite nuts	• High efficiency, high load capacity, high speed, and low noise
• Special custom motor couplers	• High torque and moment load capacity, corrects axial misalignment of the screw and motor shaft
• Reverse parallel motor mount	• Allows rear pivot or clevis mount and saves space
• Square rod	• Prevents rotation and with the bronze rod bearing, provides high durability and side load capacity
• Massive bronze rod bearing and low friction piston wear strip	• Provides side load capacity
• Dual angular load bearing	• Absorbs axial loads to protect the motor

Bimba Original Line Electric® Actuators

Bimba's Original Line Electric® Actuators are designed, built, and tested to provide the longest life, greatest durability, highest speed, and greatest thrust per dollar. They are ideal for applications requiring greater control for enhanced flexibility. OLE actuators can adapt to applications that utilize our Original Line pneumatic cylinders, and are available without motors (sized for steppers or servos), with integral step motors, and also with matching drivers.

Many popular standard features and options are available. If you need a special design feature or special adaptation, call on our custom solutions and specials design capabilities for the right product for your application. Bimba looks forward to serving your electric actuator needs with the responsiveness and engineering expertise you have come to expect from Bimba.

Mounting options:

- Four tapped holes for mounting standard
- Block front option
- Foot mount option
- Trunnion mount option
- Front pivot or clevis mount rod end kits
- Rear pivot or clevis available with reverse parallel motor mount option
- Extra rod extension
- Female thread rod end optional (male standard)

Motor options:

- Offset reverse parallel motor mounts (to conserve space)
- No motor
- Motor and encoder
- Motor and driver
- Motor, encoder, and driver

Performance options:

- Brake option (with motor) – longer lead times may apply. Compatible brakes are specified.
- Self-locking threads (selected models)
- Switches – band or track mounting
- Sealed construction option (actuator only; actuator plus motor available as a special)

Specials:

- Low backlash designs
- Guided versions
- Special motors and controls
- Washdown motors
- RoHS Compliant

Materials and Definitions

Part Name	Material
Piston	6061-T6511 aluminum
Square Rod	304 stainless steel
Motor Mount	2024-T350 aluminum
Angular Bearing	52100 steel
Rod End	303 stainless steel
Drive Nut	Acetal (Kerkite)
Coupler	17-4 PH stainless steel
Fasteners	Alloy steel and stainless steel
Washdown Cap	6061-T6511 aluminum
O-Rings	Buna-Nitrile
Wear Ring	Glass-filled Teflon
Rod Bearing	SAE 660 bronze
Drive Screw	303 stainless steel
Fasteners	18-8 stainless steel
Retaining Rings	Stainless steel, phosphate covered spring steel
Pulleys	Anodized aluminum
Belt	Nylon covered, fiberglass reinforced Neoprene
Mounting Brackets	304 stainless steel
Trunnion Pins	303 stainless steel
R, Q, S Cap	CF8 cast stainless steel
Switch Track	6063-T6 aluminum
MF Plates	2024 or 6061-T6 aluminum

Thrust - Output force of the actuator

Load – Total of all forces opposing the actuator

Repeatability – Window within which the actuator can reposition itself

Backlash – Amount of travel for the actuator with the screw held fixed (measured at the rod end)

Accuracy – Amount of error possible in linear position on screw thread

Lead – The linear distance moved for one turn of the screw

Static Load – Force required to move the mass at a constant speed

Dynamic Load – Force required to accelerate the mass

Friction Load – Force opposing motion of the mass due to surface contact

External Load – All forces not accounted for above

Weight – The force of the mass due to Earth's gravity

Stroke – The distance the mass is moved

Bimba Original Line Electric® Actuators

How to Order

The model number of all Original Line Electric® Actuators consists of alphanumeric clusters designating product type, body size (number designates maximum thrust capacity in pounds), stroke length, lead, mounting style, motor type and configuration, and options. The example below describes OLE-7512.12-50BF-T1Y2, a 75 pound maximum thrust model with 1.5 inch diameter body, 12.12 inch stroke, 0.50 inch lead, block front mount, switch track, 23 frame stepper motor with encoder, and driver. Piston magnets are included.

OLE - 75 12.12 - 50 BF - T1Y2

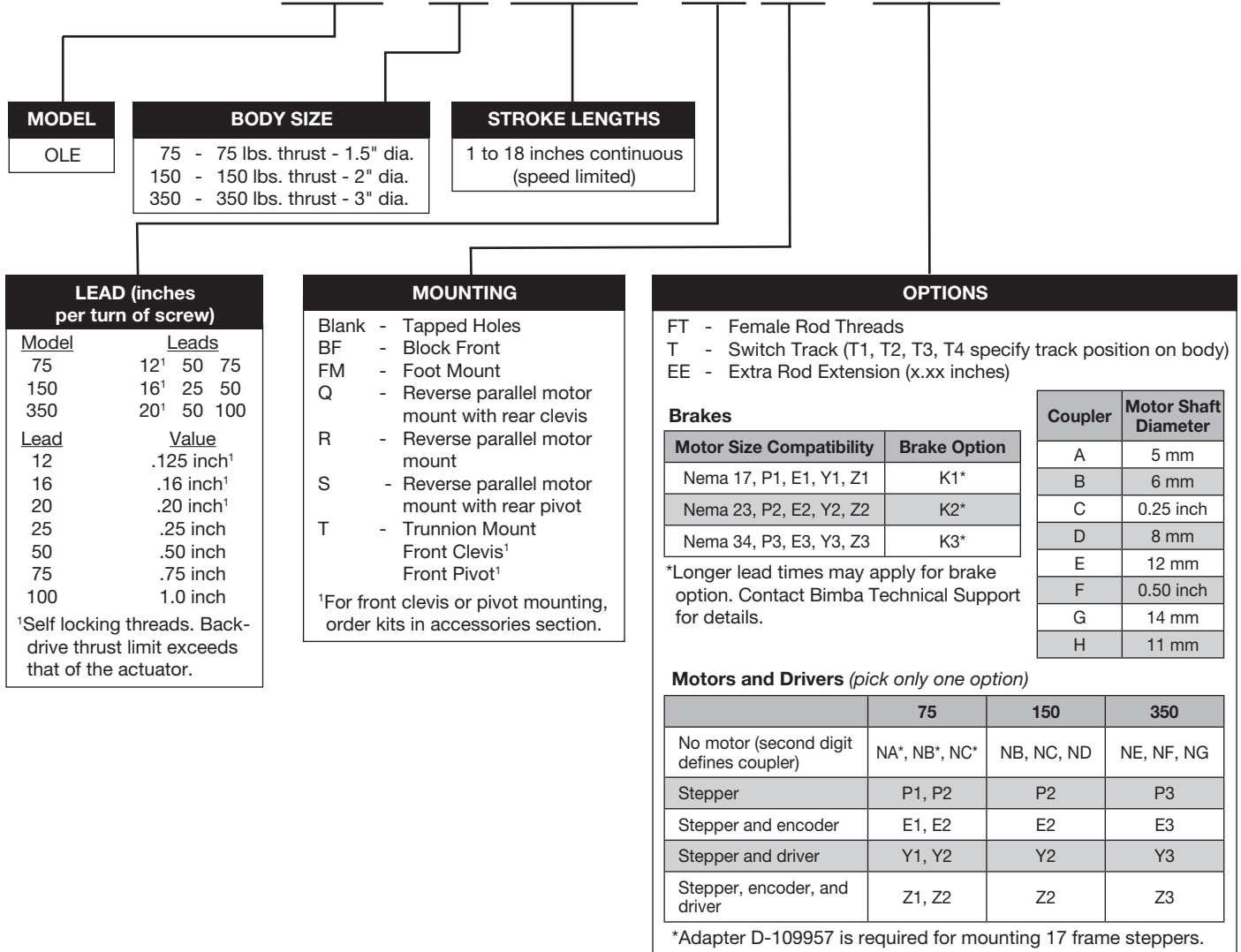

Incompatible Options - the following options cannot be ordered together.

Model	BF	FM	T*	R	S	Q	Couplers	Motors	Motor and Encoder	Motor and Driver	Motor, Encoder, and Driver
75	FM, T*	BF, T*	FM, BF	N, S, Q	N, R, Q	N, R, S	D, E, F, G	P3	E3	Y3	Z3
150	FM, T*	BF, T*	FM, BF	N, S, Q	N, R, Q	N, R, S	A, E, F, G	P1, P3	E1, E3	Y1, Y3	Z1, Z3
350	FM, T*	BF, T*	FM, BF	N, S, Q	N, R, Q	N, R, S	A, B, C, D	P1, P2	E1, E2	Y1, Y2	Z1, Z2

Model	K1	K2	K3
75	N_, P2, E2, Y2, Z2	N_, P1, E1, Y1, Z1	N_, P1, P2, E1, E2, Y1, Y2, Z1, Z2
150	N_, P2, E2, Y2, Z2		N_, P2, E2, Y2, Z2
350	N_, P3, E3, Y3, Z3	N_, P3, E3, Y3, Z3	

*Trunnion

Bimba Original Line Electric® Actuators

List Prices

Model, No Motor	Base Price	Stroke adder per inch	Mounting Options			Reverse Parallel Motor Mount			K	EE
			BF	FM	T	R	S	Q		
			Block Front	Foot Mount	Trunnion Mount	Standard	Rear Pivot	Rear Clevis	Brake	Extra Extension (per inch)
OLE-75x-12x-x ¹	\$299.00	\$15.00	\$20.00	\$40.00	\$40.00	\$120.00	\$120.00	\$120.00	\$485.00	\$5.00
OLE-75x-50x-x	299.00	15.00	20.00	40.00	40.00	120.00	120.00	120.00	485.00	5.00
OLE-75x-75x-x	299.00	15.00	20.00	40.00	40.00	120.00	120.00	120.00	485.00	5.00
OLE-150x-16x-x ¹	399.00	20.00	25.00	45.00	45.00	150.00	150.00	150.00	535.00	9.00
OLE-150x-25x-x	399.00	20.00	25.00	45.00	45.00	150.00	150.00	150.00	535.00	9.00
OLE-150x-50x-x	399.00	20.00	25.00	45.00	45.00	150.00	150.00	150.00	535.00	9.00
OLE-350x-20x-x ¹	549.00	25.00	30.00	50.00	50.00	180.00	180.00	180.00	745.00	12.00
OLE-350x-50x-x	549.00	25.00	30.00	50.00	50.00	180.00	180.00	180.00	745.00	12.00
OLE-350x-100x-x	549.00	25.00	30.00	50.00	50.00	180.00	180.00	180.00	745.00	12.00

¹Self-locking threads

No Charge - Female Rod Thread, No Motor Option

For anodized aluminum or stainless steel construction, contact Bimba Technical Support.

Model, Motor Adder	Switch Track	Step Motor			Step Motor and Driver			Step Motor and Encoder			Step Motor, Encoder, and Driver		
Alphanumeric Cluster	T	P1	P2	P3	Y1	Y2	Y3	E1	E2	E3	Z1	Z2	Z3
Frame		Size 17	Size 23	Size 34	Size 17	Size 23	Size 34	Size 17	Size 23	Size 34	Size 17	Size 23	Size 34
OLE-75x-12x-x ¹	\$8.00	\$50.00	\$90.00		\$250.00	\$330.00		\$152.00	\$192.00		\$350.00	\$440.00	
OLE-75x-50x-x	8.00	50.00	90.00		250.00	330.00		152.00	192.00		350.00	440.00	
OLE-75x-75x-x	8.00	50.00	90.00		250.00	330.00		152.00	192.00		350.00	440.00	
OLE-150x-16x-x ¹	8.00		90.00			330.00			192.00			440.00	
OLE-150x-25x-x	8.00		90.00			330.00			192.00			440.00	
OLE-150x-50x-x	8.00		90.00			330.00			192.00			440.00	
OLE-350x-20x-x ¹	8.00			239.00			500.00			351.00			630.00
OLE-350x-50x-x	8.00			239.00			500.00			351.00			630.00
OLE-350x-100x-x	8.00			239.00			500.00			351.00			630.00

¹Self-locking threads

Accessories

Clevis Pin

Part Number	For Model	List Price
RS-CP500	75, 150	\$14.45
RS-CP750	350	24.10

Rod Eye

Part Number	For Model	List Price	Mating Bkt.	List Price
RS-RE437	75	\$24.25	ACB-1	\$23.05
RS-RE500	150	24.25	ACB-1	23.05
RS-RE750	350	59.35	ACB-2	41.75

Adapter Plate

Part Number	For Model	List Price
D-109957	75	\$31.20
D-109960	75	31.20
D-109968	75	31.20
D-109958	150	46.80
D-111352	150	31.20
D-109959	350	62.40
D-111353	350	31.20

Rod Clevis

Part Number	For Model	List Price	Mating Bkt.	List Price
RS-RC437	75	\$44.00	APB-1	\$21.35
RS-RC500	150	44.00	APB-1	21.35
RS-RC750	350	102.60	APB-2	33.30

MF1 Mounting Flange

(Allows OLE to front mount to standard NFPA MF1 dimensions.)

Part Number	For Model	List Price
MFEA-75	75	\$88.40
MFEA-150	150	92.60
MFEA-350	350	99.85

OLE actuators are designed for 1500 miles life at continuous duty, 23° C (73° F), clean dry ambient, and 15% below the published speed/thrust curve. Higher ambient temperatures, higher speeds, higher loads, and the presence of moisture and contaminants will cause accelerated wear. The actual life of the actuator in an application is dependent upon all these factors which must be considered prior to sizing the actuator.

Bimba Original Line Electric® Actuators

Specifications and Sizing

No Motor Option (N)

Base Part Number	Lead ² (inches)	Backlash ³ (inches)	Screw Accuracy (in./in.)	Screw Repeatability (micro inches)	Maximum Load (lbs.)	Actuator Inertia Adder (oz-in ²)	Actuator Inertia per inch (oz-in ²) ⁴
OLE-75-xx-12xx-Nx ¹	.125	.003	0.0006	50	75	.003	.006
OLE-75-xx-50xx-Nx	.50	.005	0.0006	50	75	.003	.006
OLE-75-xx-75xxx-Nx	.75	.007	0.0006	50	75	.003	.006
OLE-150-xx-16xx-Nx ¹	.16	.005	0.0006	50	150	.218	.021
OLE-150-xx-25xx-Nx	.25	.006	0.0006	50	150	.218	.021
OLE-150-xx-50xx-Nx	.50	.008	0.0006	50	150	.218	.021
OLE-350-xx-20xx-Nx ¹	.20	.003	0.0006	50	350	1.588	.103
OLE-350-xx-50xx-Nx	.75	.005	0.0006	50	350	1.588	.103
OLE-350-xx-100xx-Nx	1.0	.007	0.0006	50	350	1.588	.103

Operating temperature range: -20° F to 160° F (-29° C to 71° C)
 Standard IP rating: None
 Maximum stroke: 18 inches
 RoHS compliant

¹Self-locking threads

²Inches per revolution of screw

³Amount of end play on screw. Low backlash designs are available. Contact Technical Support.

⁴Inertia is given per inch of stroke

Caution! When specifying actuator stroke before ordering, always add at least 1/8 inch to the full stroke required in your application. The actuator should not reach mechanical end of stroke during extend or retract. Repeatedly reaching mechanical end of stroke, especially under load at operating speeds, may damage the actuator.

Sizing your actuator and specifying the right motor

The following procedure is for sizing an actuator and arriving at a single-point speed/torque specification for a motor **not** supplied by Bimba. Speed and thrust performance of Bimba's standard motor and actuator combinations may not be equivalent.

1. Determine the thrust, maximum speed, and stroke your application requires. Overstating speed and thrust will make your actuator more expensive than it needs to be. Understating the speed and thrust will compromise performance and durability.
2. Use the "Speed versus Thrust" graph. Actuators' curves that are ABOVE your speed/thrust data point are usable. Curves below the data point are not.

You have just identified the series of actuator (75, 150, or 350) that is best suited for your application.

3. Use the "Thrust versus Torque" graphs for the actuator series identified above. Select the lead (inches per turn of the screw) that will provide the thrust you require with the minimum motor torque.
4. Use the "Speed versus RPM" graphs for the actuator series and lead you selected. Find the motor speed in RPM required to provide the actuator speed (inches per second) using the chosen lead (inches per rev). You might need to evaluate several different OLE series or leads in order to identify an achievable speed/torque motor specification.

Bimba Original Line Electric[®] Actuators

Speed Versus Thrust

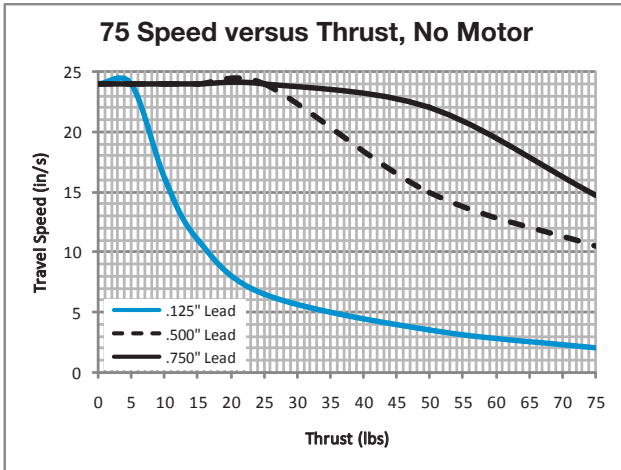

Thrust vs. Torque

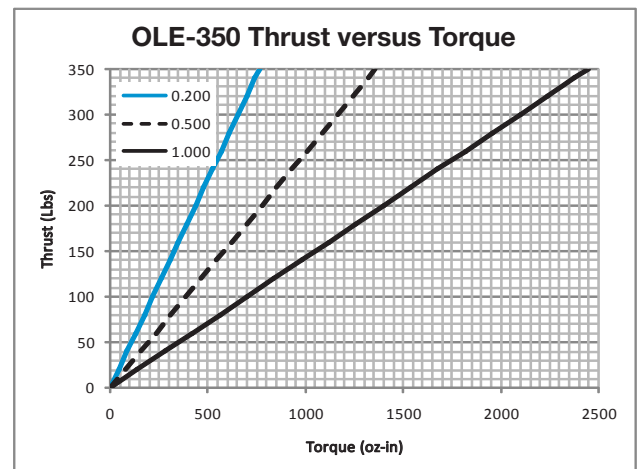
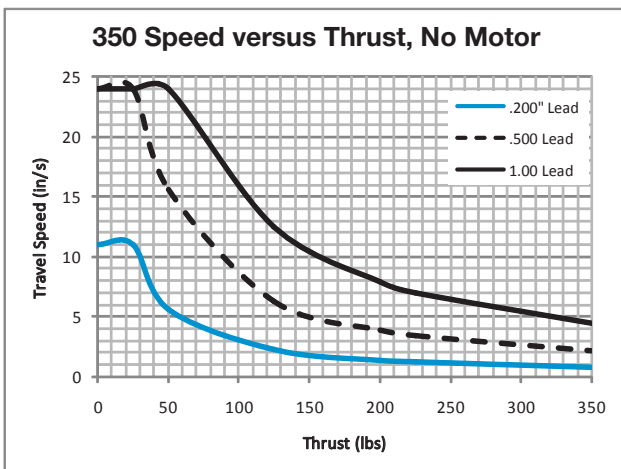
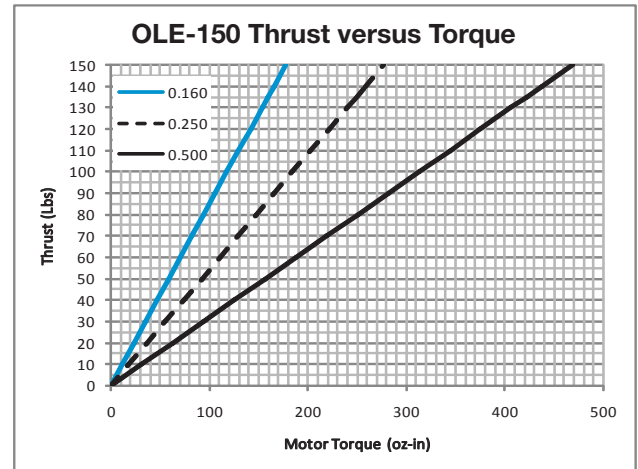
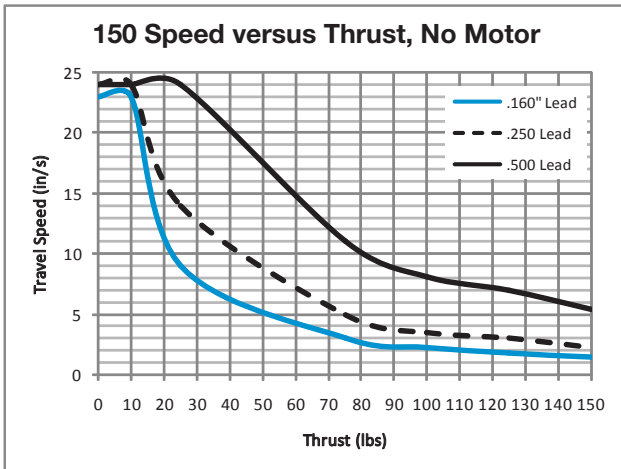
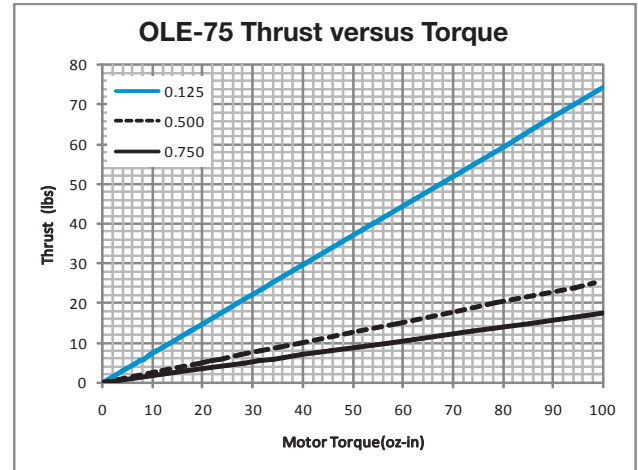

Note: The curves above are based on a number of design factors, including the PV limit of the nut and the maximum torque compatibility of the coupler. Other factors combine to limit speed. Do not exceed thrust/speed values shown in above graphs as damage to actuator may result.

Bimba Original Line Electric[®] Actuators

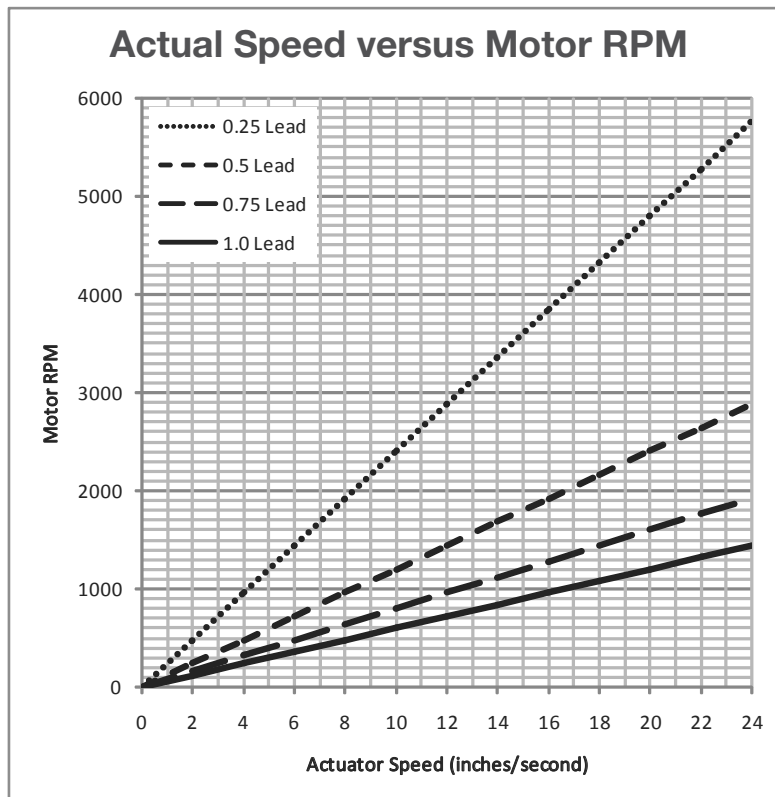
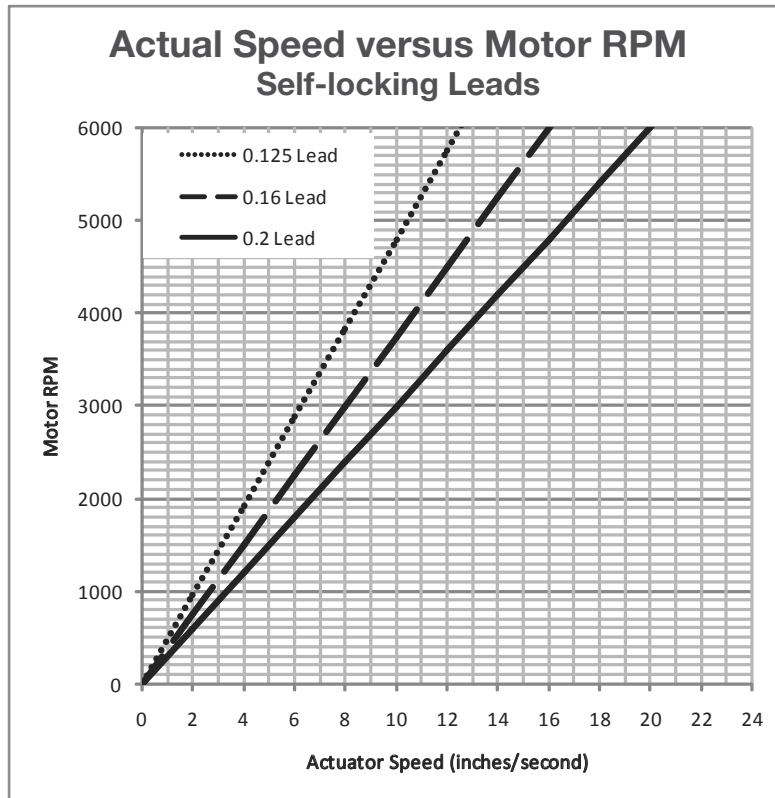

Bimba Original Line Electric® Actuators

Specifications and Sizing

Step Motor and Motor/Driver Options (P, E, Y, Z)

Base Part Number	Lead ² (inches)	Backlash ³ (inches)	Screw Accuracy (in./in.)	Screw Repeatability (micro inches)	Actuator Inertia Adder (oz-in ²)	Actuator Inertia per inch (oz-in ²) ⁴	Motor Inertia Adder (oz-in ²) ⁵	Maximum Current Draw ⁶
OLE-75-xx-12xx-P1 ¹	.125	.003	0.0006	50	.003	.006	.44	1.7
OLE-75-xx-50xx-P1	.50	.005	0.0006	50	.003	.006	.44	1.7
OLE-75-xx-75xxx-P1	.75	.007	0.0006	50	.003	.006	.44	1.7
OLE-75-xx-12xx-P2 ¹	.125	.003	0.0006	50	.003	.006	2.51	4.24
OLE-75-xx-50xx-P2	.50	.005	0.0006	50	.003	.006	2.51	4.24
OLE-75-xx-75xxx-P2	.75	.007	0.0006	50	.003	.006	2.51	4.24
OLE-150-xx-16xx-P2 ¹	.16	.005	0.0006	50	.218	.021	2.51	4.24
OLE-150-xx-25xx-P2	.25	.006	0.0006	50	.218	.021	2.51	4.24
OLE-150-xx-50xx-P2	.50	.008	0.0006	50	.218	.021	2.51	4.24
OLE-350-xx-20xx-P3 ¹	.20	.003	0.0006	50	1.588	.103	15.03	5.6
OLE-350-xx-50xx-P3	.50	.005	0.0006	50	1.588	.103	15.03	5.6
OLE-350-xx-100xx-P3	1.0	.007	0.0006	50	1.588	.103	15.03	5.6

Operating temperature range: 32° F to 122° F (0° C to 50° C) limited by the driver. If the driver is remotely mounted and protected from heat, maximum operating temperature will be 160° F (71° C).

Maximum stroke: 18 inches

RoHS compliant

¹Self-locking threads

²Inches per revolution of screw

³Amount of end play on screw

⁴Inertia is given per inch of stroke

⁵Inertia for motor by itself

⁶For driver sizing for actuators supplied without drivers

Caution! When specifying actuator stroke before ordering, always add at least 1/8 inch to the full stroke required in your application. The actuator should not reach mechanical end of stroke during extend or retract. Repeatedly reaching mechanical end of stroke, especially under load at operating speeds, may damage the actuator.

Bimba Original Line Electric[®] Actuators

Specifications and Sizing

Step Motor and Motor/Driver Options (P, E, Y, Z)

Speed/Thrust Performance Vertical Orientation, Pounds and Inches/Second Maximum Continuous

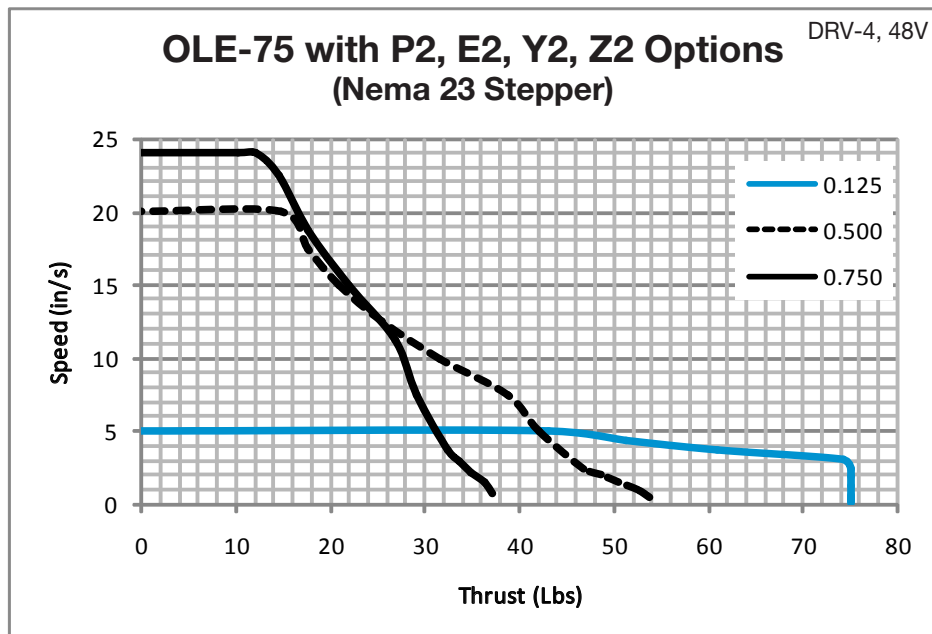
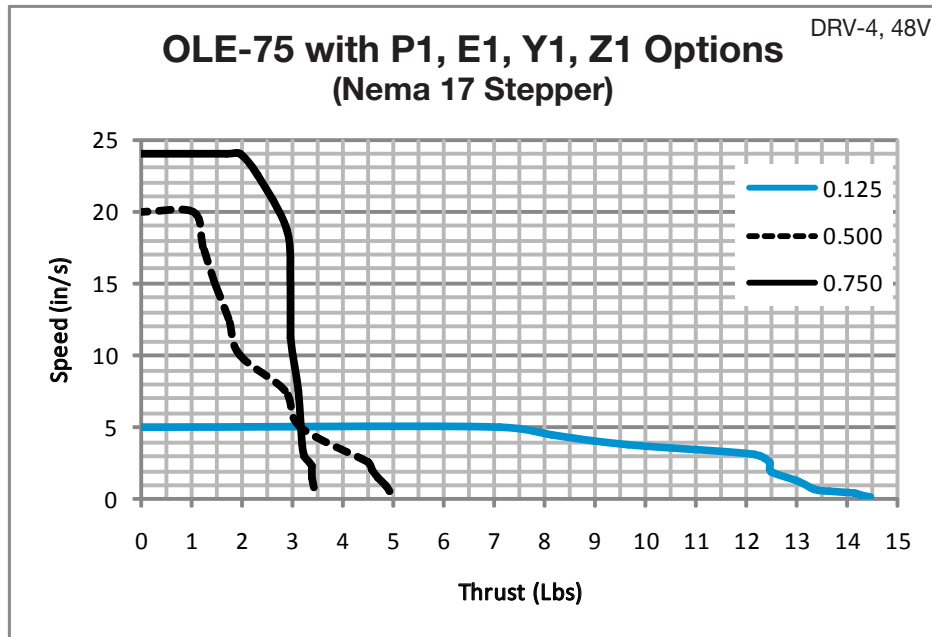

Bimba Original Line Electric[®] Actuators

Specifications and Sizing

Step Motor and Motor/Driver Options (P, E, Y, Z)

Speed/Thrust Performance Vertical Orientation, Pounds and Inches/Second Maximum Continuous

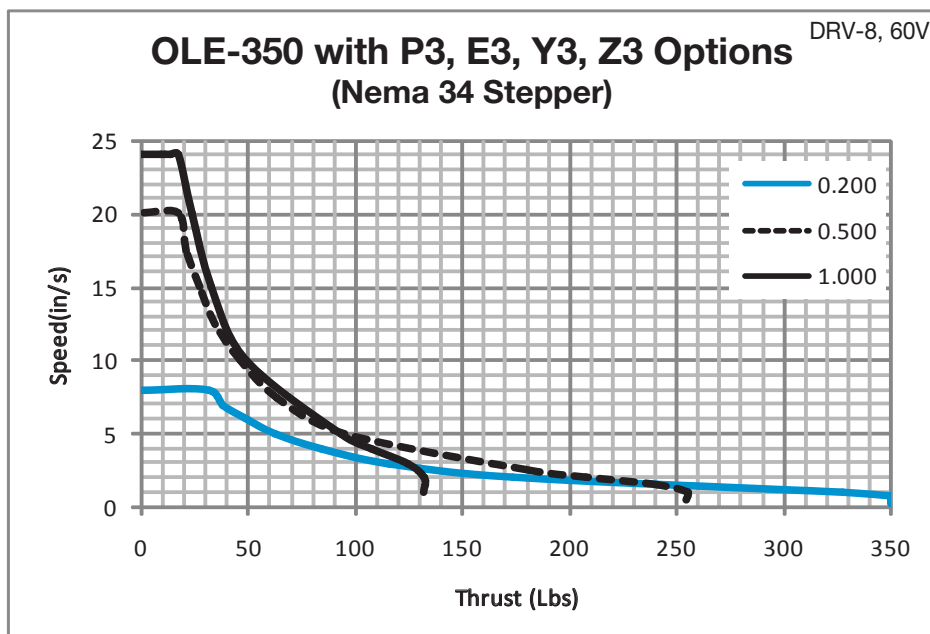
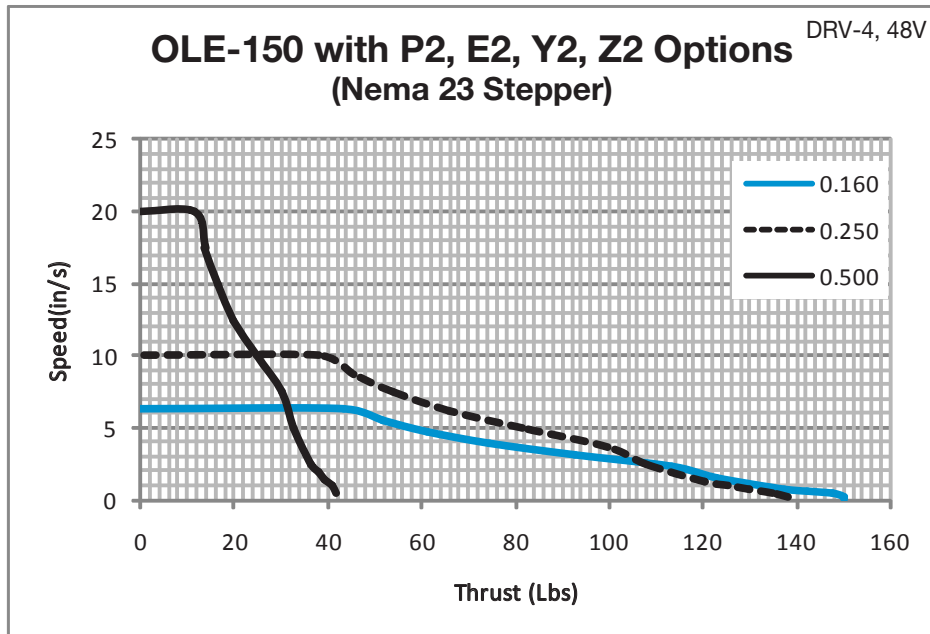

Bimba Original Line Electric® Actuators

Specifications and Sizing

Reverse Parallel Motor Option (R, S, Q & P, E, Y, Z)

Base Part Number	Lead ² (inches)	Backlash ³ (inches)	Screw Accuracy (in./in.)	Screw Repeatability (micro inches)	Actuator Inertia Adder (oz-in ²) ⁴	Actuator Inertia per inch (oz-in ²) ⁵	Motor Inertia Adder (oz-in ²) ⁶	Maximum Current Draw ⁷
OLE75-xx-12Rx-P1 ¹	.125	.003	0.0006	50	.096	.006	.44	1.7
OLE75-xx-50Rx-P1	.50	.005	0.0006	50	.096	.006	.44	1.7
OLE75-xx-75Rx-P1	.75	.007	0.0006	50	.096	.006	.44	1.7
OLE75-xx-12Rx-P2 ¹	.125	.003	0.0006	50	.096	.006	2.51	4.24
OLE75-xx-50Rx-P2	.50	.005	0.0006	50	.096	.006	2.51	4.24
OLE75-xx-75Rx-P2	.75	.007	0.0006	50	.096	.006	2.51	4.24
OLE150-xx-16Rx-P2 ¹	.16	.005	0.0006	50	1.01	.021	2.51	4.24
OLE150-xx-25Rx-P2	.25	.006	0.0006	50	1.01	.021	2.51	4.24
OLE150-xx-50Rx-P2	.50	.008	0.0006	50	1.01	.021	2.51	4.24
OLE350-xx-20Rx-P3 ¹	.20	.003	0.0006	50	9.51	.103	15.03	5.6
OLE350-xx-50Rx-P3	.50	.005	0.0006	50	9.51	.103	15.03	5.6
OLE350-xx-100Rx-P3	1.0	.007	0.0006	50	9.51	.103	15.03	5.6

Operating temperature range: 32° F to 122° F (0° C to 50° C). If the driver is remotely mounted and protected from heat, maximum operating will be 158° F (70° C).
 Maximum stroke: 18 inches
 RoHS compliant

¹Self-locking threads

²Inches per revolution of screw

³Amount of end play on screw

⁴Inertia for reverse parallel option

⁵Inertia is given per inch of stroke

⁶Inertia for motor by itself

⁷For driver sizing for actuators supplied without drivers

Caution! When specifying actuator stroke before ordering, always add at least 1/8 inch to the full stroke required in your application. The actuator should not reach mechanical end of stroke during extend or retract. Repeatedly reaching mechanical end of stroke, especially under load at operating speeds, may damage the actuator.

Bimba Original Line Electric[®] Actuators

Specifications and Sizing

Reverse Parallel Motor Option (R, S, Q & P, E, Y, Z)

Speed/Thrust Performance Vertical Orientation, Pounds and Inches/Second Maximum Continuous

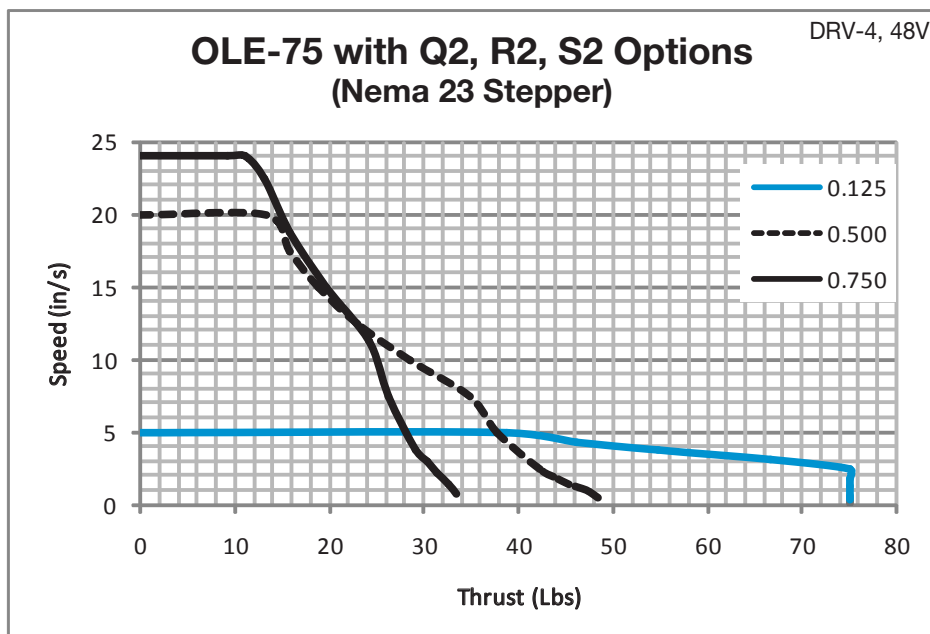
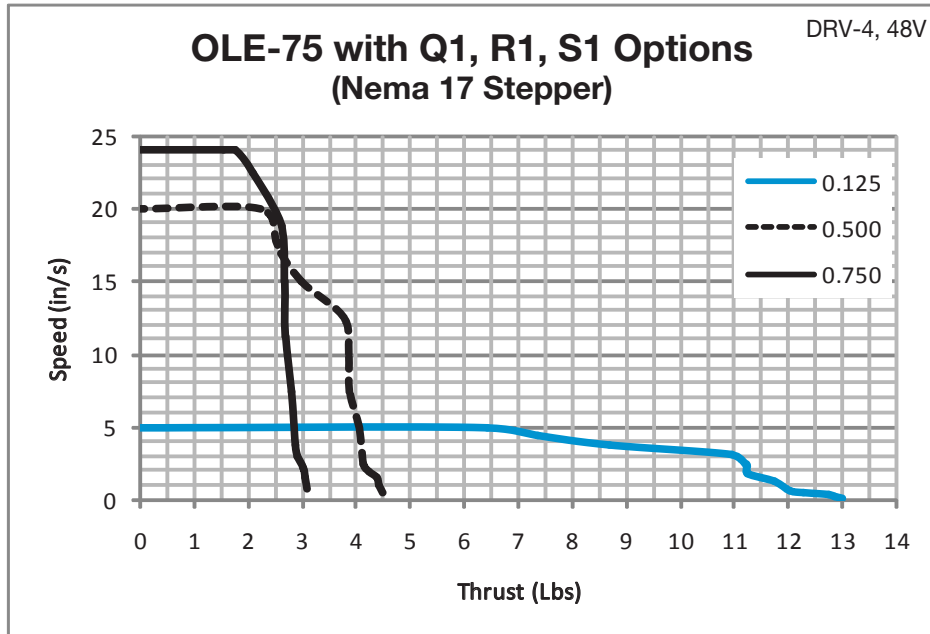

Bimba Original Line Electric[®] Actuators

Specifications and Sizing

Reverse Parallel Motor Option (R, S, Q & P, E, Y, Z)

Speed/Thrust Performance Vertical Orientation, Pounds and Inches/Second Maximum Continuous

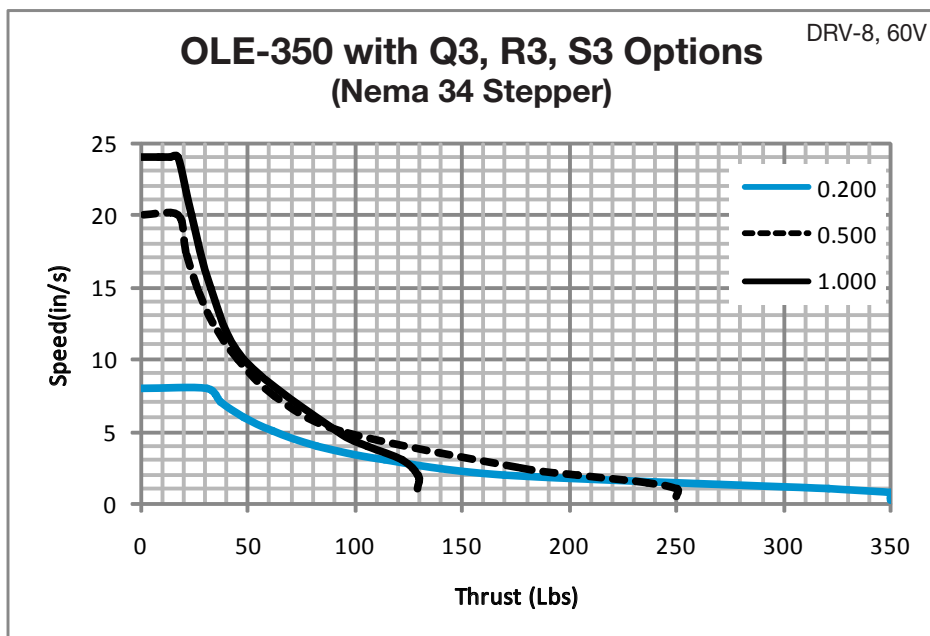
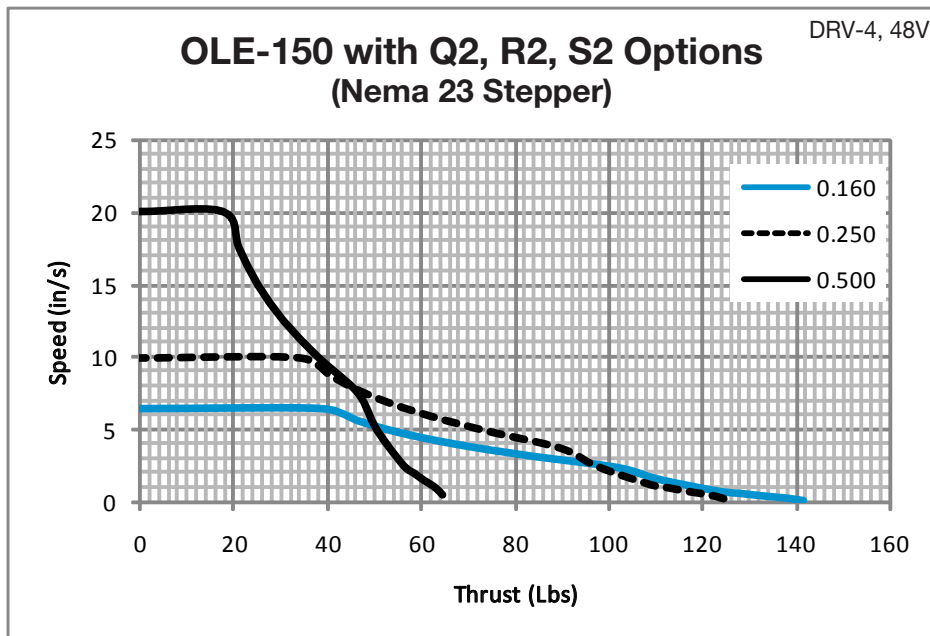

Bimba Original Line Electric® Actuators

Specifications and Sizing

Driver Option (Y and Z)

Bimba DRV drives are the simplest OEM control solution. Drivers are shipped matched to and configured for the actuator purchased. No software or programming is required. Just provide DC power, attach the motor leads, and connect step and direction (or step clockwise and counterclockwise) inputs and it is ready to run. They are ideal for use with PLC stepper cards.

- Step and direction inputs
- Step clockwise and step counterclockwise inputs (jumper selectable)
- Separate output that signals a fault condition
- Input to disable power to the motor windings
- Accepts step inputs from 200 to 20,000 steps per revolution of the motor
- Micro step emulation on two settings
- Adjustable running current, 70 to 100%
- Adjustable idle current, 50% to 90% of running current
- Selectable load inertia settings
- Self-test feature to verify all connections are correct and actuator is operational
- Optically isolated I/O
- Digital filters prevent position error from electrical noise on command signals
- Electronic damping and anti-resonance



Driver	DCV Input	Bimba Option	Parallel Current Draw	Max. Parallel Current Draw	24V Power Supply Amps	48V Power Supply Amps	Maximum Amps per Phase	Recommended Power Supply
DRV-4	24-48	Y1,Y2,Z1,Z2	1.7	3.4	4	2	4.5	150 (W)
DRV-8	24-75	Y3,Z3	5.6	11.2	12	6	7.8	320 (W)

Microstepping provides smoothest rotation. However, a faster step pulse rate (frequency) is required for a given RPM as shown in the table below. The 200 μ and 400 μ setting use microstep emulation to provide smooth rotation at low speeds. Microstep emulation imparts a slight delay to the motion. If this is not acceptable, use the non-filtered 200 or 400 settings.

Pulses per Revolution: Relationship to Speed and Pulse Frequency			
Pulses per Revolution	Degrees per Step	Pulse Frequency Required for 300 RPM	Pulse Frequency for 3000 RPM
200	1.8	1,000 Hz	10,000 Hz
400	0.9	2,000 Hz	20,000 Hz
2000	0.18	10,000 Hz	100,000 Hz
5000	0.072	25,000 Hz	250,000 Hz
12800	0.028	64,000 Hz	640,000 Hz
20000	0.018	100,000 Hz	1,000,000 Hz

Bimba Original Line Electric[®] Actuators

Model DRV Specifications

- Amplifier** Digital MOSFET. 20 kHz PWM. Suitable for driving two phase and four phase step motors with four, six or eight leads.
Supply voltage:
DRV-4
24-48 VDC
Under voltage alarm: 20 VDC
Over voltage shutdown: 60 VDC
DRV-8
24-75 VDC
Under voltage alarm: 20 VDC
Over voltage shutdown: 85 VDC
- Motor current:
0.5 to 7.8 amps/phase peak of sine (DRV8)
0.25 to 4.5 amps/phase peak of sine (DRV4)
- Digital Inputs** Optically isolated, 5 - 24V logic. Sourcing, sinking or differential signals can be used.
Minimum "on" voltage: 4 VDC.
Maximum voltage: 30 VDC.
Input current: 5 mA typ at 4V, 15 mA typ at 30V.
- Fault Output** Photodarlington, 80 mA, 30 VDC max. Voltage drop: 1.2V max at 80 mA.
- Physical** 1.3 x 3.0 x 4.65 inches (33 x 75.5 x 118 mm) overall. 10.8 oz (305 g) including mating connectors.
Ambient temperature range: 0° C to 50° C (32° F to 122° F).

Mating Connectors

Motor/power supply: PCD P/N ELV06100 (Phoenix Contact 1757051), included with drive.

Signals: PCD P/N ELVH08100 (Phoenix Contact 1803633), included with drive.

Note: DRV drive does not accept encoder feedback.

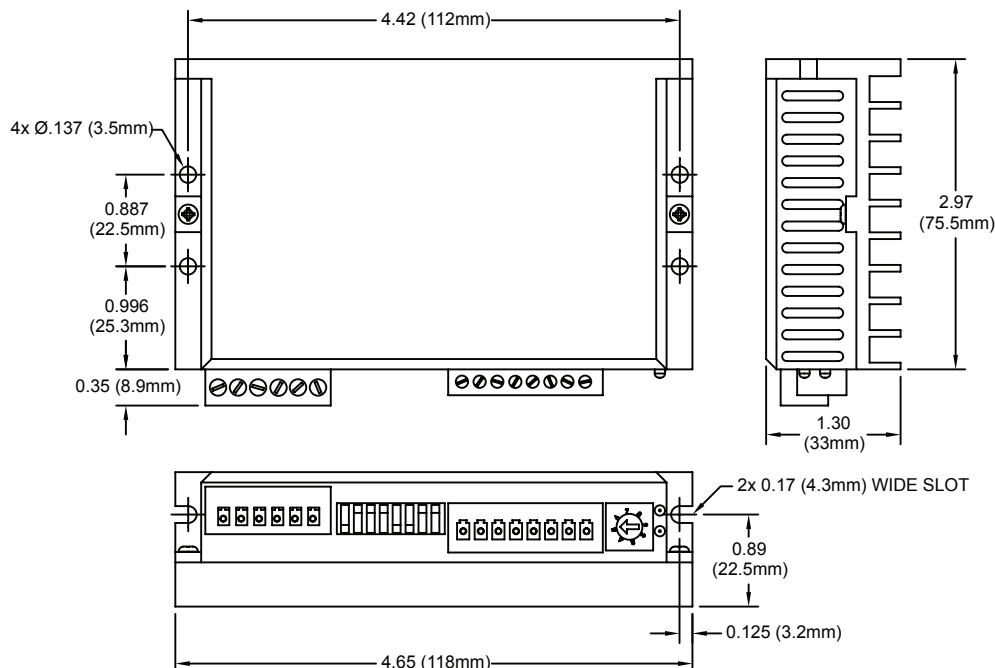

Bimba Original Line Electric® Actuators

Dimensions

No Motor (N)

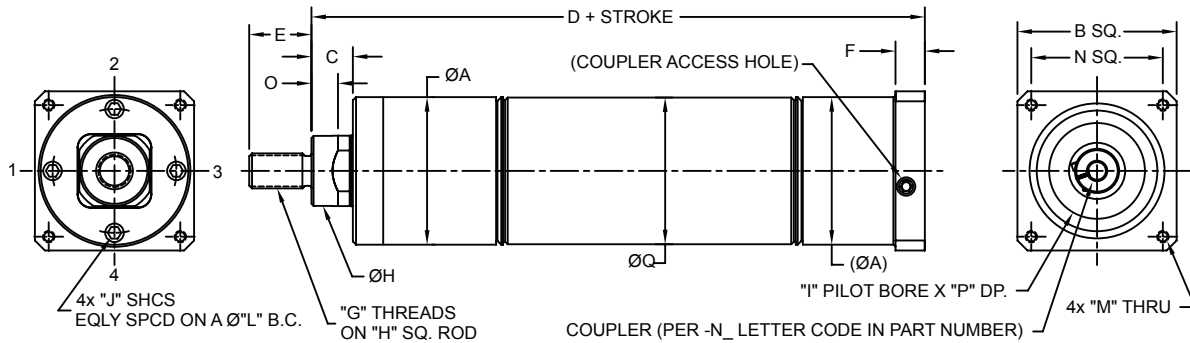

Model	A	B	C	D	E	F	G	H	I	J	K	L	M	N	O	P	Q
75	1.56	2.25	0.58	5.75	1.00	0.25	7/16-20 UNF	0.74	1.502	#8-32 UNC	0.30	1.25	#8-32 UNC	1.86	0.21	0.13	1.56
150	2.09	2.25	0.59	7.84	0.88	0.42	1/2-20 UNF	1.00	1.502	#10-24 UNC	0.38	1.75	#8-32 UNC	1.86	0.30	0.13	2.07
350	3.13	3.39	0.87	10.11	1.13	0.55	3/4-16 UNF	1.50	2.878	1/4-20 UNC	0.50	2.50	#10-24 UNC	2.74	0.38	0.15	3.10

Motors (P and Y Options)

Add motor dimensions to no motor actuator dimensions.

17 Frame Stepper Motor (P1)

23 and 34 Frame Stepper Motor (P2/P3)

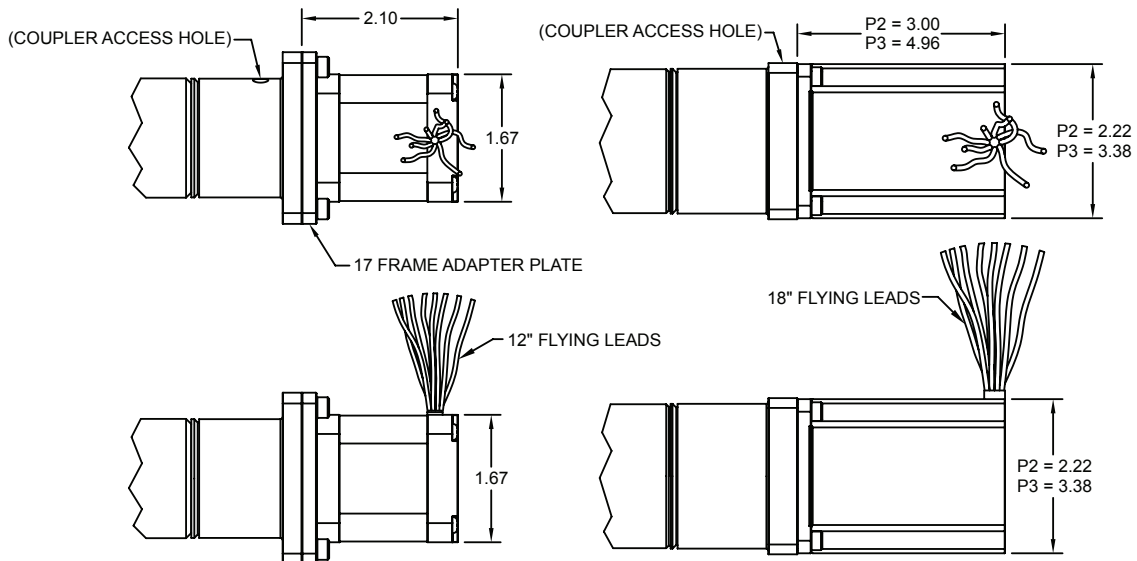

Bimba Original Line Electric[®] Actuators

Dimensions

Motor and Encoder (E and Z Options)

Add motor and encoder dimensions below to no motor actuator dimensions.

17 Frame Stepper Motor (E1, Z1)

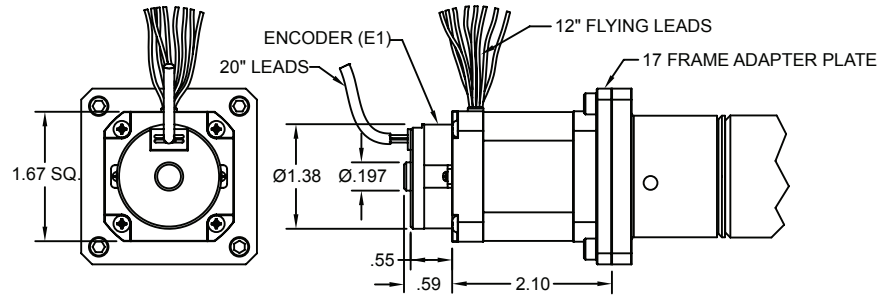

23 Frame Stepper Motor (E2, Z2)

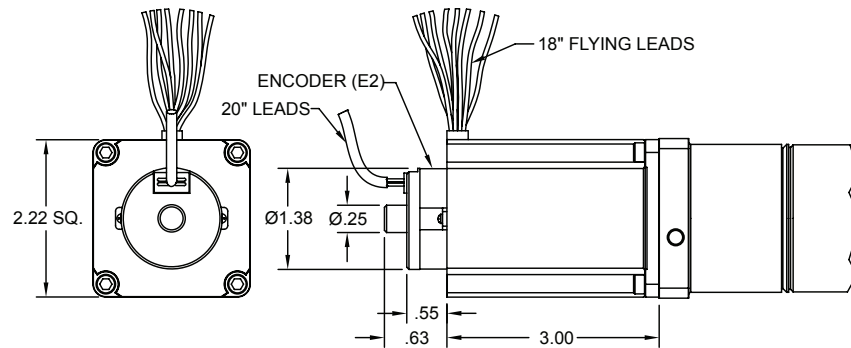

34 Frame Stepper Motor (E3, Z3)

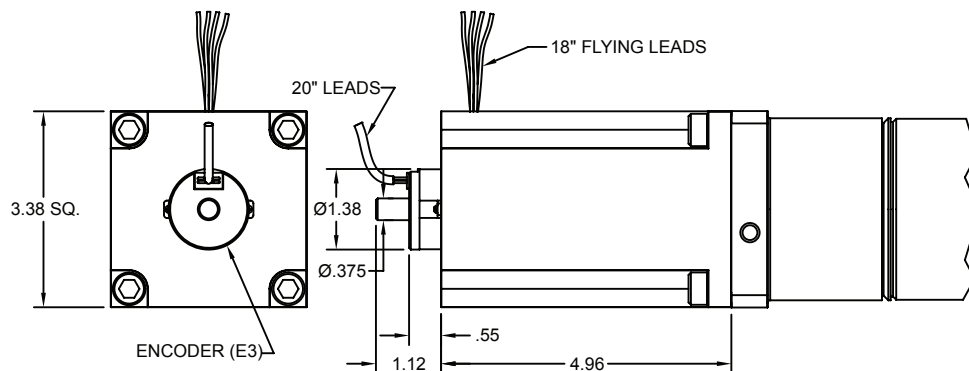

Bimba Original Line Electric[®] Actuators

Dimensions

Brake (K Option)

Add motor and brake dimensions below to no motor actuator dimensions.

17 Frame Stepper and Brake (K1)

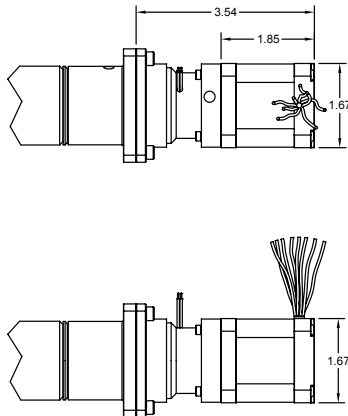

23 and 34 Frame Stepper and Brake (K2/K3)

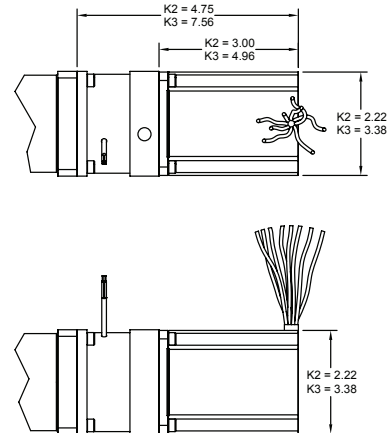

Switch Track (T1, T2, T3, T4 Options)

Numbers indicate the position of the switch track relative to the plug that provides access to the coupler.

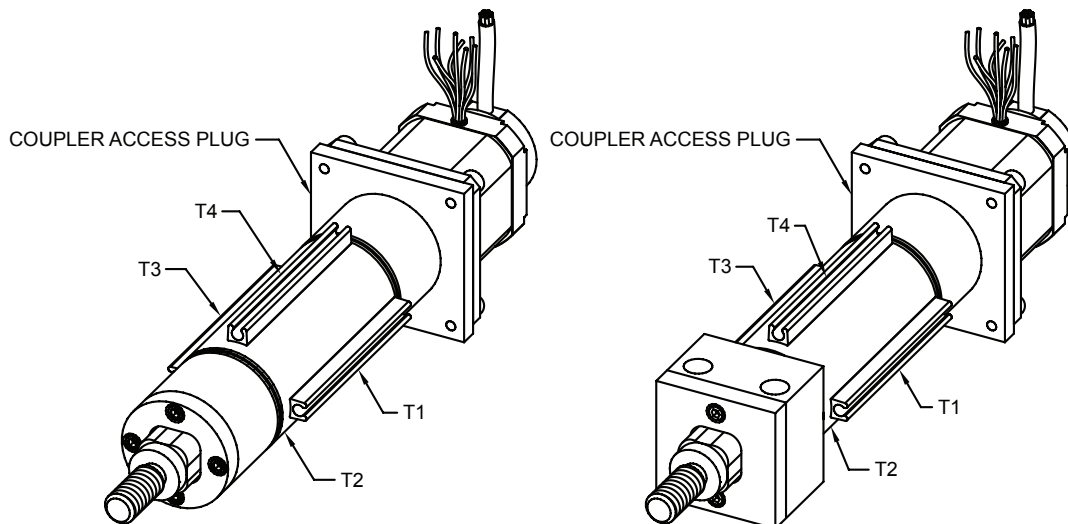

For use with Bimba MR, MS, MSC, or MSK track mount switches.

Bimba Original Line Electric[®] Actuators

Dimensions

Reverse Parallel Motor Mounting (R, S, and Q Options)

Add reverse parallel dimensions to no motor actuator dimensions.

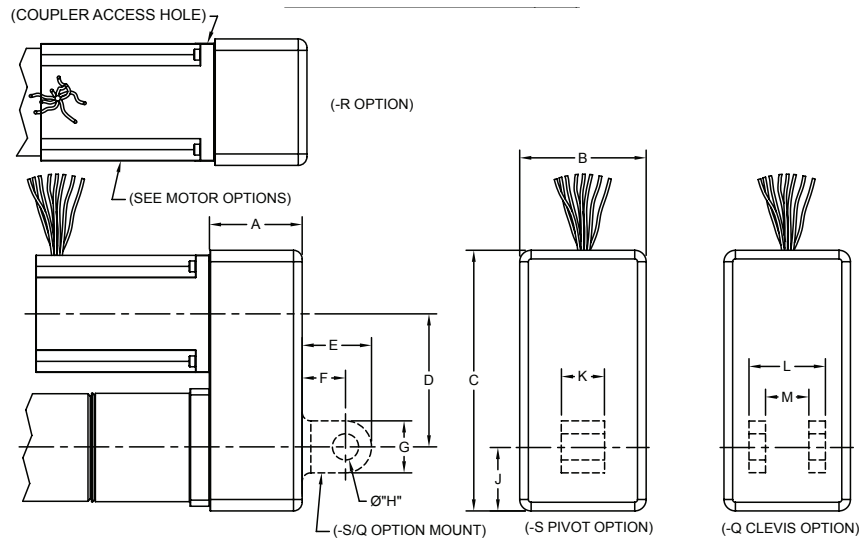

Motor	A	B	C	D	E	F	G	H	J	K	L	M
P1	1.50	2.61	4.60	1.99	1.25	0.75	1.00	0.50	1.31	0.75	1.75	0.76
P2	1.65	2.59	5.14	2.56	1.25	0.75	1.00	0.50	1.31	0.75	1.75	0.76
P3	2.65	3.65	7.52	3.86	2.00	1.25	1.50	0.75	1.85	1.25	2.50	1.26

Bimba Original Line Electric® Actuators

Dimensions Mounting Options

Female Rod End (FT)

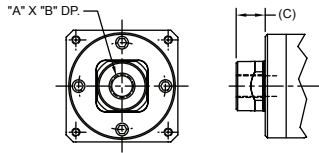

Block Front (BF) for 75, 150

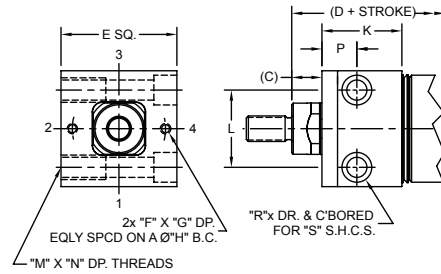

Trunnion Mount (T)

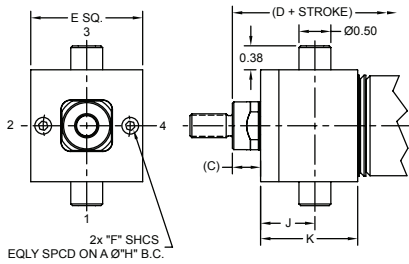

Block Front (BF) for 350

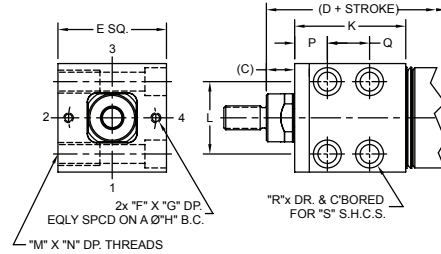

Model	A	B	C	D	E	F	G	H	J	K	L	M	N	P	Q	R	S
75	7/16-20 UNF	.75	0.58	5.75	1.75	#8-32 UNC	.30	1.25	0.67	1.34	1.13	5/16-18 UNC	0.63	0.813	n/a	2	#10
150	1/2-20 UNF	.65	0.59	7.84	2.25	#10-24 UNC	.38	1.75	1.00	2.00	1.50	7/16-20 UNF	0.63	1.25	n/a	2	3/8
350	3/4-16 UNF	.85	0.87	10.11	3.50	1/4-20 UNC	.50	2.50	1.25	2.50	2.63	9/16-18 UNF	1.13	0.72	0.86	4	1/2

Foot Mount

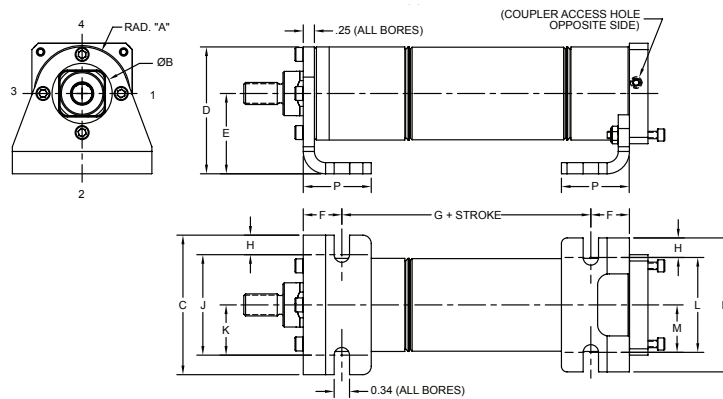

Model	A	B	C	D	E	F	G	H	J	K	L	M	N	P
75	0.78	1.00	2.75	2.40	1.63	0.94	3.29*	0.31	2.13	1.06	2.13	1.06	2.75	1.52
150	1.04	1.35	3.13	2.84	1.80	0.86	5.37*	0.44	2.25	1.13	2.13	1.06	3.01	1.52
350	1.56	2.00	4.38	3.61	2.05	1.06	6.82*	0.44	3.50	1.75	3.50	1.75	4.38	1.68

Bimba Original Line Electric[®] Actuators

Accessories

Rod Clevis

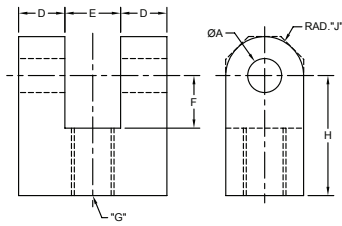

Model	Part No.	A	D	E	F	G	H	J
75	RS-RC437	0.50	0.50	0.75	0.75	7/16-20	1.50	0.50
150	RS-RC500					1/2-20		
350	RS-RC750	0.75	0.63	1.25	1.25	3/4-16	2.38	0.75

Clevis Pin

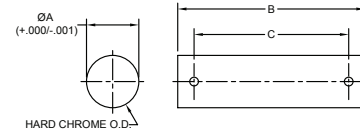

Model	Part No.	A	B	C
75, 150	RS-CP500	0.50	2.25	1.94
350	RS-CP750	0.75	3.00	2.72

(Clevis pins sold with (2) S.S. cottter pins)

Mating Pivot Bracket

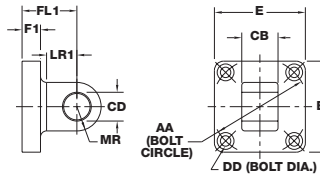

Model	Part No.	AA	CB	CD	DD	E	F1	FL1	LR1	MR
75, 150	APB-1	2.00	0.75	0.50	0.19	1.88	0.38	1.12	0.745	0.50
350	APB-2	2.83	1.25	0.75	0.312	2.75	0.50	1.88	1.10	0.69

Rod Eye

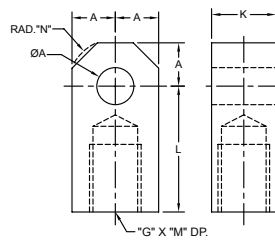

Model	Part No.	A	K	L	G	M	N
75	RS-RE437	0.50	0.75	1.50	7/16-20	0.75	0.63
150	RS-RE500				1/2-20		
350	RS-RE750	0.75	1.25	2.06	3/4-16	1.13	0.88

Mating Clevis Bracket*

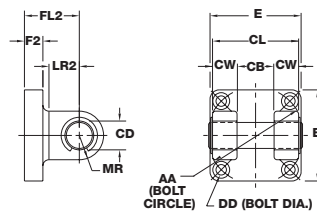

Model	Part No.	AA	CB	CD	CL	CW	DD	E	F2	FL2	LR2	MR
75, 150	ACB-1	2.00	0.75	0.50	1.75	0.50	0.19	1.88	0.38	1.12	0.745	0.50
350	ACB-2	2.83	1.25	0.75	2.50	0.62	0.312	2.75	0.38	1.25	0.85	0.69

*Includes case hardened pin

Bimba Original Line Electric® Actuators

Accessories

Adapter Plates

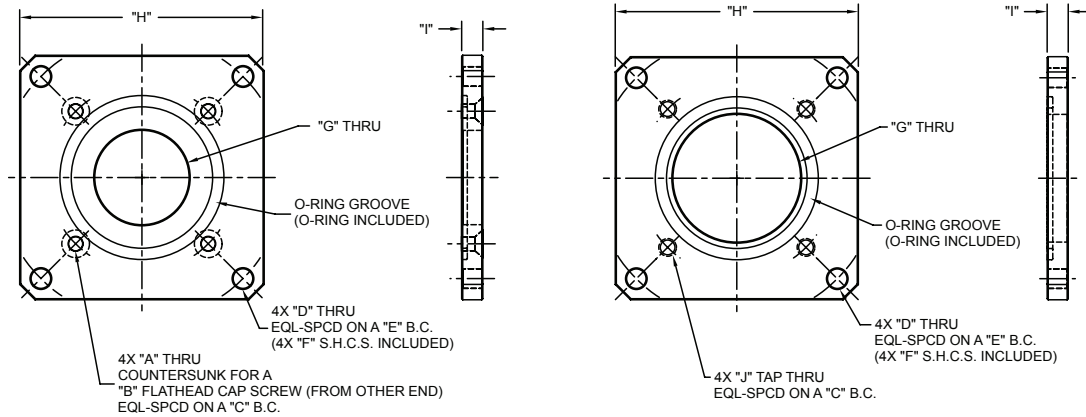

Part No.	A	B	C	D	E	F	G	H	I	J
D-109957	.13	#4	1.73	.18	2.63	#8	.87	2.25 SQ.	.20	N/A
D-109958	N/A	N/A	1.81	.18	2.63	#8	1.18	2.25 SQ.	.20	#8-32 UNC-2B
D-109959	N/A	N/A	2.76	.20	3.87	#10	1.97	3.39 SQ.	.30	#10-24 UNC-2B
D-109960	.17	#8	1.41	.18	2.63	#8	.99	2.25 SQ.	.20	N/A
D-109968	.18	#8	1.73	.18	2.63	#8	.87	2.25 SQ.	.20	N/A
D-111352	N/A	N/A	1.77	.18	2.63	#8	1.18	2.25 SQ.	.20	M3
D-111353	N/A	N/A	2.76	.20	3.87	#10	1.97	3.39 SQ.	.30	#8-32 UNC-2B

MF1 Mounting Plate

(Allows OLE to front mount to standard NFPA MF1 dimensions.)

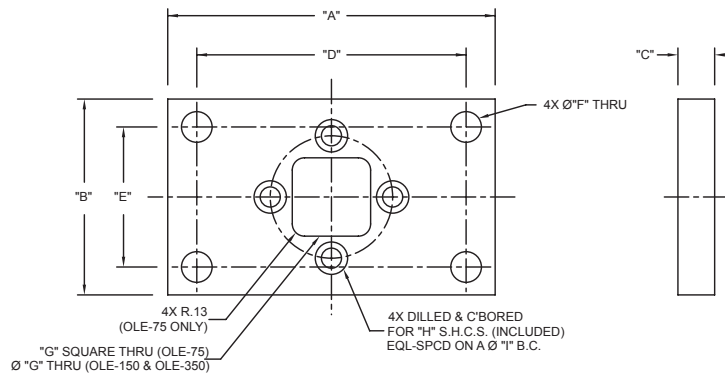

Part Number	Model	A	B	C	D	E	F	G	H	I
MFEA-75	75	3.34	2.00	0.38	2.75	1.43	0.31	0.80	#8	1.25
MFEA-150	150	4.09	2.50	0.38	3.38	1.84	0.38	1.35	#10	1.75
MFEA-350	350	5.47	3.75	0.63	4.69	2.76	0.44	2.00	1/4	2.50

Bimba Original Line Electric® Actuators

Motor Schematics Wiring Diagrams and Specifications (supplied with P, E, Y, and Z options)

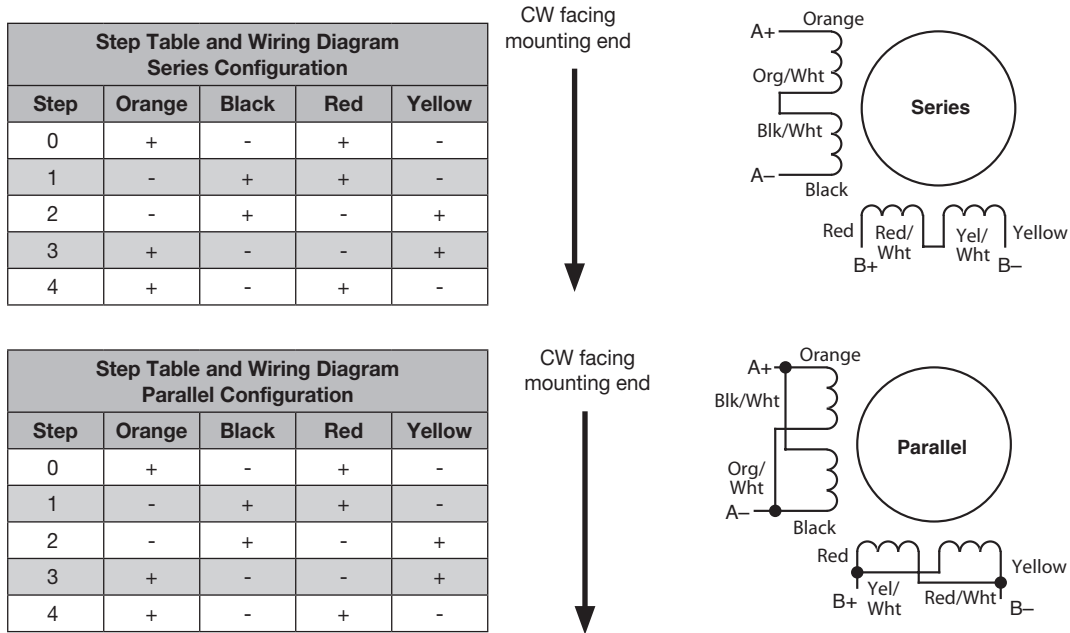

Specifications for Bimba 8-lead 1.8 degree step motors are provided in the following table.

Frame	Winding Connection	Minimum Holding Torque (oz-in)	Potential (Volts)	Current (Amps)	Resistive (Ohms)	Inductance (mH)	Rotor Inertia (oz-in ² /g-cm ²)
17	Parallel	62.3	2.9	1.70	1.7	2.5	0.44/82
	Series	62.3	5.6	0.85	6.6	10.0	0.44/82
	Unipolar	43.9	4.0	1.20	3.3	2.5	0.44/82
23	Parallel	269.1	2.1	4.24	0.5	1.7	2.51/460
	Series	269.1	4.2	2.12	2.0	6.8	2.51/460
	Unipolar	191.2	3.0	3.0	1.0	1.7	2.51/460
34	Parallel	1260	2.72	5.6	0.48	5.4	15.0/2750
	Series	1260	5.43	2.8	1.94	21.6	15.0/2750
	Unipolar	906	3.88	4.0	0.97	5.4	15.0/2750

Bimba Original Line Electric® Actuators

Encoder Connections and Specifications

(supplied with E and Z options)

Encoder connections, All Steppers

Encoder connections for all Bimba steppers with encoders are identified below. The cable provided has flying leads which can be connected to your controller.

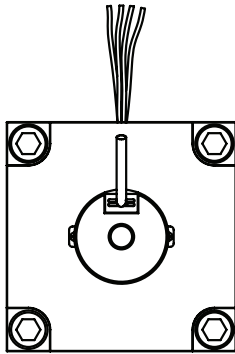

Pin No.	Wire Color	Function
1	Yellow	Channel A
2	Yellow/White	Channel A-
3	Blue	Channel B
4	Blue/White	Channel B-
5	Orange	Index
6	Orange/White	Index-
7	Green	Not used
8	Green/White	
9	Brown	
10	Brown/White	
11	White	
12	Gray/White	
13	Red	+5 V DC input power
14	Black	Encoder ground
15	Gray	Drain/shield

Encoder Specifications

If you have ordered your actuator with a motor/encoder combination, the encoder specifications are listed below.

Power Input	5 V DC, 160 mA
Resolution	2000 pulses per rev.
Output High	2.5 V DC Min.
Output Low	0.5 V DC Max.
Operating Frequency	500 kHz Max.
Operating Temperature	-30 to 115°C
Enclosure Rating	IP40

Brake Connections and Specifications

(supplied with K1, K2, and K3 options)

Bimba K_-option brakes are available only when ordered with Bimba step motors as part of an OLE actuator model. They are not available if the no-motor actuator option is selected. With no power applied to the brake, motor shaft and actuator screw rotation are immobilized to the limit of the holding torque specification in the table below. To release the shaft and screw and allow rotation, the operating voltage (24 VDC) must be applied to the two brake leads. Drawings of the brakes are provided on page 17 of this catalog.

Brake Option	Nema Size	Holding Torque (oz-in.)	Inertia (oz-in ²)	Operating Voltage	Resistance (Ohms)	Current Draw (Amps)
K1	17	16	0.0384	24 VDC	117	0.220
K2	23	48	0.1392	24 VDC	132	0.182
K3	34	240	1.792	24 VDC	65.1	0.369

Bimba Original Line Electric® Actuators

Motor Compatibility Chart

For selecting the right actuator with other brands of motors

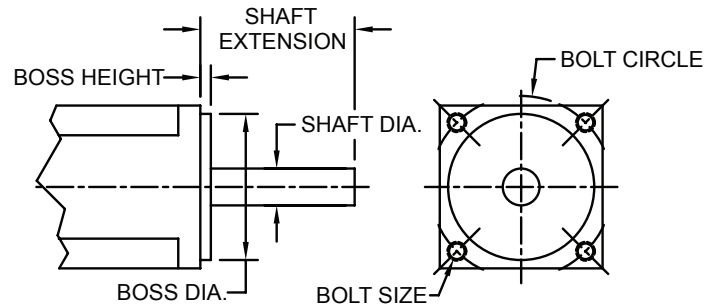

Step Motors

Ordering Information					Performance with 1/2 inch lead		Motor Performance	
Stepper Brand	Stepper Model	Motor Size	Actuator P/N	Adapter P/N	Thrust (lbs)	Speed (in/sec)	Max Torque (in-oz)	Max Speed (RPM)
Applied Motion	HT17-075	17	OLE-75x-(50)x-NA	D-109957	6	0.3	47	2400
Applied Motion	HT23-401	23	OLE-150x-(50)x-NC	None Required	135	0.5	210	2400
Applied Motion	HT34-478	34	OLE-350x-(50)x-NF	None Required	350	0.5	1284	2400
Lin	4118C-01	17	OLE-75x-(50)x-NA	D-109957	TBD	TBD	102.8	900
Lin	5718L-03P	23	OLE-150x-(50)x-NC	None Required	45	5	210	1200
Lin	8718L-08P	34	OLE-350x-(50)x-NF	None Required	185	2	1000	720
Sanyo Denki	103H5210-52	17	OLE-75x-(50)x-NA	D-109957	20	0.5	70	3000
Sanyo Denki	103H7128	23	OLE-150x-(50)x-NC	None Required	75	0.5	300	1583
Sanyo Denki	SM2863-522	34	OLE-350x-(50)x-NG	None Required	TBD	TBD	1100	2100

Motor Mounting Dimensions										
Stepper Brand	Stepper Model	Motor Size	Actuator P/N	Adapter P/N	Shaft Diameter (in)	Shaft Extension (in)	Boss Diameter (in)	Boss Height (in)	Bolt Size	Bolt Circle
Applied Motion	HT17-075	17	OLE-75x-(50)x-NA	D-109957	5mm (.1968)	0.787	.865/.866	0.079	#4-40 Tapped	1.22 Sq
Applied Motion	HT23-401	23	OLE-150x-(50)x-NC	None Required	0.25	0.787	1.499/1.501	0.063	0.205	1.86 Sq
Applied Motion	HT34-478	34	OLE-350x-(50)x-NF	None Required	0.50	1.46	2.874/2.876	0.08	0.26	2.74 Sq
Lin	4118C-01	17	OLE-75x-(50)x-NA	D-109957	5mm (.1968)	0.94	0.864/0.866	0.08	M3 Tapped	1.22 Sq
Lin	5718	23	OLE-150x-(50)x-NC	None Required	0.25	0.81	1.499/1.501	0.06	0.2	1.86 Sq
Lin	8718	34	OLE-350x-(50)x-NF	None Required	0.50	1.46	2.874/2.876	0.08	0.26	2.74 Sq
Sanyo Denki	103H5210-52	17	OLE-75x-(50)x-NA	D-109957	5mm (.1968)	0.94	0.868/0.870	0.06	M3 Tapped	1.22 Sq
Sanyo Denki	103H7128	23	OLE-150x-(50)x-NC	None Required	0.25	0.81	1.499/1.501	0.06	.18/.2	1.86 Sq
Sanyo Denki	SM2863-522	34	OLE-350x-(50)x-NG	None Required	14mm (.551)	1.18	2.874/2.876	0.06	0.22	2.74 Sq

Bimba Original Line Electric® Actuators

Motor Compatibility Chart

For selecting the right actuator with other brands of motors

Servo Motors

Ordering Information				Performance with 1/2 inch lead		Motor Performance	
Servo Brand	Servo Model	Actuator P/N	Adapter P/N	Thrust (lbs)	Speed (in/sec)	Max Torque (in-oz)	Max Speed (RPM)
Allen Bradley	TLY-A130T-AA	OLE-150x-(50)x-ND	D-109958	29	50	46	6000
Allen Bradley	TLY-A130T-AN	OLE-75x-(50)x-NC	D-109968	29	50	46	6000
Allen Bradley	TLY-A230T-AN	OLE-350x-(50)x-NE	D-109959	117	50	184	6000
Allen Bradley	TLY-A2540P	Special ¹	Special			416	5000
Lin	BL17B40	OLE-75x-(50)x-NA	D-109960	26	33	41	4000
Lin	BL24B46-01	OLE-150x-(50)x-NC	None Required	54	33	87.8	4000
Lin	BL25B19-01	OLE-150x-(50)x-NC	Special	21	33	34	4000
Mitsubishi	HC-KFS13	OLE-150x-(50)x-ND	D-109958	28	25	45	3000
Mitsubishi	HC-KFS43	OLE-350x-(50)x-NG	D-109959	114	25	184	3000
Mitsubishi	HC-KFS73	Special ¹	Special	221	25	340	3000
Mitsubishi	HC-MFS053(B)	OLE-150x-(50)x-ND	D-109958	27	25	22.6	3000
Mitsubishi	HC-MFS43(B)	OLE-350x-(50)x-NG	D-109959	155	25	184	3000
Mitsubishi	HC-MFS73	Special ¹	Special			339	3000
Panasonic	MSMD5A_1_	OLE-150x-(50)x-ND	D-111352	14	42	68	5000
Panasonic	MSMD01_1_	OLE-150x-(50)x-ND	D-111352	28	42	136	5000
Panasonic	MSMD021_1_	OLE-350x-(50)x-NH	D-111353	52	42	272	5000
Panasonic	MSMD041_1_	OLE-350x-(50)x-NG	D-111353	105	42	552	5000
Sanyo Denki	Q1AA06040D	OLE-350x-(50)x-NG	D-109959	111	25	180	3000
Sanyo Denki	Q2EA04010D	OLE-150x-(50)x-NB	D-109958	28	25	45	3000
Sanyo Denki	Q2AA08100D	Special ¹	Special	293	25	450	3000
Yaskawa	SGMJV-01A	OLE-150x-(50)x-ND	D-109958	28	25	67.5	3000
Yaskawa	SGMJV-04A	OLE-350x-(50)x-NG	D-109959	111	25	247	3000

Motor Mounting Dimensions									
Servo Brand	Servo Model	Actuator P/N	Adapter P/N	Shaft Diameter (in)	Shaft Extension (in)	Boss Diameter (in)	Boss Height (in)	Bolt Size	Bolt Circle
Allen Bradley	TLY-A130T-AA	OLE-150x-(50)x-ND	D-109958	8mm	0.98	1.180/1.181	0.1	0.177	1.811
Allen Bradley	TLY-A130T-AN	OLE-75x-(50)x-NC	D-109968	0.25	1.063	0.866	0.08	8-32 Tapped	1.725
Allen Bradley	TLY-A230T-AN	OLE-350x-(50)x-NE	D-109959	12mm	1.181	1.967/1.968	0.12	0.26	2.76
Allen Bradley	TLY-A2540P	Special ¹	Special	16mm(.630)	1.378	2.754/2.755	0.12	0.26	3.94
Lin	BL17B40	OLE-75x-(50)x-NA	D-109960	5mm	0.83	0.988	0.12	M4	1.00 Sq
Lin	BL24B46-01	OLE-150x-(50)x-NC	None Required	0.25	0.81	1.499/1.500	0.06	0.2	1.86 Sq
Lin	BL25B19-01	OLE-150x-(50)x-NC	Special	0.25	0.81	2.124/2.128	0.06	0.2	1.95 Sq
Mitsubishi	HC-KFS13	OLE-150x-(50)x-ND	D-109958	8mm	0.98	1.180/1.181	0.098	0.177	1.811
Mitsubishi	HC-KFS43	OLE-350x-(50)x-NG	D-109959	14mm(.551)	1.181	1.967/1.968	0.118	0.228	2.755
Mitsubishi	HC-KFS73	Special ¹	Special	19mm(.748)	1.575	2.755/2.756	0.118	0.26	3.543
Mitsubishi	HC-MFS053(B)	OLE-150x-(50)x-ND	D-109958	8mm	0.94	1.181	0.098	0.177	1.811
Mitsubishi	HC-MFS43(B)	OLE-350x-(50)x-NG	D-109959	14mm(.551)	1.181	1.967/1.968	0.118	0.228	2.756
Mitsubishi	HC-MFS73	Special ¹	Special	19mm(.748)	1.574	2.754/2.755	0.118	0.26	3.543
Panasonic	MSMD5A_1_	OLE-150x-(50)x-ND	D-111352	8 mm	30 mm	1.811	0.12	0.13	1.811
Panasonic	MSMD01_1_	OLE-150x-(50)x-ND	D-111352	8 mm	30 mm	1.811	0.12	0.13	1.811
Panasonic	MSMD021_1_	OLE-350x-(50)x-NH	D-111353	11 mm	50 mm	1.969	0.12	0.18	2.756
Panasonic	MSMD041_1_	OLE-350x-(50)x-NG	D-111353	14 mm	50 mm	1.969	0.12	0.18	2.756
Sanyo Denki	Q1AA06040D	OLE-350x-(50)x-NG	D-109959	14mm(.551)	1.181	1.967/1.968	0.118	0.216	2.755
Sanyo Denki	Q2EA04010D	OLE-150x-(50)x-NB	D-109958	6mm	0.98	1.180/1.181	0.098	0.177	1.811
Sanyo Denki	Q2AA08100D	Special ¹	Special	16mm(.630)	1.378	3.148/3.150	0.118	0.26	3.937
Yaskawa	SGMJV-01A	OLE-150x-(50)x-ND	D-109958	8mm	0.984	1.181	0.098	0.169	1.811
Yaskawa	SGMJV-04A	OLE-350x-(50)x-NG	D-109959	14mm(.551)	1.181	1.967/1.968	0.118	0.216	2.756

Notes

Notes

Notes

Warranty

All Bimba Original Line Electric® products, including but not limited to cataloged standard products are warranted against defects in workmanship or material under normal conditions and usage for a period of one year from the date of shipment. Bimba product that has been repaired at the Bimba factory carries a warranty against defects in workmanship and materials for a period of one year from the date of shipments.

Extend your warranty to two years by registering on our website at: www.bimba.com

Bimba makes no express or implied warranty of merchantability and no express or implied warranty that the product shall be fit for any particular purpose and no other express or implied warranties which extend beyond the description on the face hereof, all of which have been expressly disclaimed. Bimba makes no warranty as to the appropriateness of the product as an integral part of any sub-assembly or assembly, or other end product.

This warranty does not extend to any product which has been subject to misuse, tampering, accident, abuse, neglect, normal wear and tear, abnormal use, improper machining, improper installation, improper storage, improper maintenance or other application in a way that does not meet the normal use of the product or is at variance from documented specifications, drawings and test procedures.

Bimba's liability with respect to the product proved to its satisfaction to be defective shall be limited to repair, replacement, or refund of the purchase price, at Bimba's election, and in no event shall Bimba's liability exceed the purchase price of the product. Bimba shall not be subject to any other obligations or liabilities, whether arising out of breach of contract or warranty, tort (including negligence), or other theories of law with respect to products sold or services rendered by Bimba, or any undertakings, acts or omissions relating thereto. Without limiting the generality of the foregoing, Bimba specifically disclaims all liability for property or personal injury damages, penalties, special or punitive damages, and damages for lost profits or other forms of economic loss. Bimba shall not be liable for any consequential, incidental, indirect, compensatory or contingent damages whatsoever, even if it has been advised of the possibility of such damages.

Product enhancements resulting from our continuing quality improvement effort may necessitate changes in specification without notice.

All product is sold F.O.B. shipping point. Prices are subject to change without notice.

This warranty shall be governed by the laws of the State of Illinois and Bimba expressly disclaims the application of the United Nations Convention on contracts for the international sale of goods (ciscg).

CAD Drawings

**CAD drawings (2D and 3D) can be downloaded from our web site at
www.bimba.com**

**For Support Call:
800-44-BIMBA (800-442-4622)**

(United States, Mexico and Canada)

708-534-8544

or via e-mail at support@bimba.com

**Product and catalog updates can be downloaded from
www.bimba.com**

Your stocking distributor is:



Bimba Manufacturing Company

P.O. Box 68
Monee, Illinois 60449-0068
Phone: 708-534-8544
Toll Free: 800-44-BIMBA
Fax: 708-235-2014
Email: support@bimba.com
www.bimba.com



Worldwide distribution means there is a professional stocking
Bimba distributor nearby ready to service your needs.